



KONICA MINOLTA

# DRYPRO $\Sigma$ II

✓ DRY LASER IMAGER



Giving Shape to Ideas

# DRYPRO $\Sigma$ II

**DRYPRO ΣII is a new design in the range of Konica Minolta's Dry Laser Imagers that fits the needs of medical professionals looking for a high resolution table top printer.**

The DRYPRO ΣII creates images of unrivalled sharpness, utilizing the latest precision optics from Konica

Minolta to produce a 50-μm pixel pitch; the highest available resolution.

The new compact and highly efficient Laser Imager is easy to operate, offers an intuitive workflow and is available with a wide range of film sizes.



**High-Quality images 50-μm**

A semiconductor laser is used to produce a 50-μm pixel pitch (508 dpi), resulting in high image resolution.

Powerful image-processing algorithms are utilized to simultaneously optimize both the image smoothness as well as the text sharpness.

Diagnostic clarity is preserved and patient data is always readable, regardless of the print size.

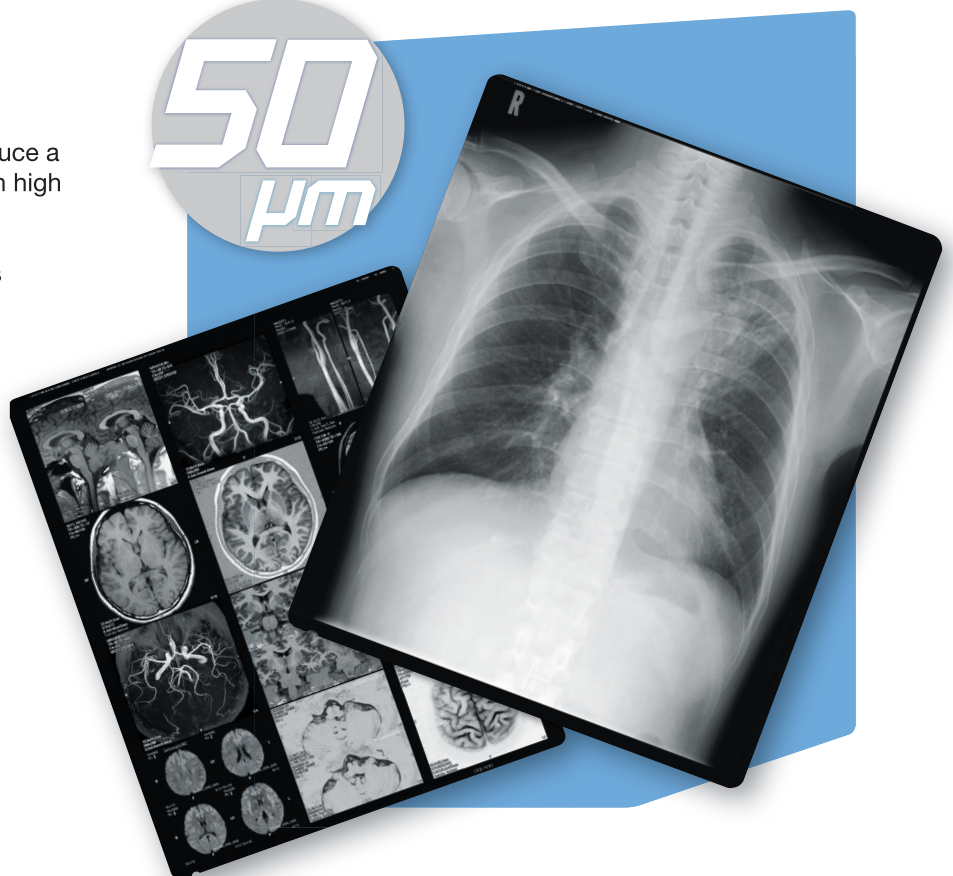

**Four film sizes and two trays**

Variety of four film sizes: 14x17", 11x14", 10x12" and 8x10".

The DRYPRO ΣII is equipped with two film trays so that two different film sizes can be used simultaneously.

**Consistent quality**

The DRYPRO ΣII density control function maintains the output density via automatic measurement. The system also automatically calibrates whenever a tray of film with a new lot-number is loaded.

**User-friendly design**

The DRYPRO ΣII is easy to operate and offers an intuitive workflow. Film exchange requires a simple cartridge insertion. The innovative cartridges allow easy film size adjustment and support various modalities such as CR, CT, Ultrasound and MRI.

**Space-saving & fast**

DRYPRO ΣII is a desktop printer and combines reliability and convenience with remarkable operating efficiency, all in a compact body. It features a



footprint as small as 65 x 63 cm<sup>2</sup> and is designed for use in small clinics and high throughput general hospitals with a speed up to 110 sheets/hour (for 8 x 10").

**Network functions designed for open and flexible environments**

DRYPRO ΣII is a networked imager, capable of connecting directly to DICOM print compliant devices. In addition to DICOM basic grayscale print functions, the DRYPRO ΣII supports Presentation LUT, which enables printed film to more accurately match diagnostic monitors.

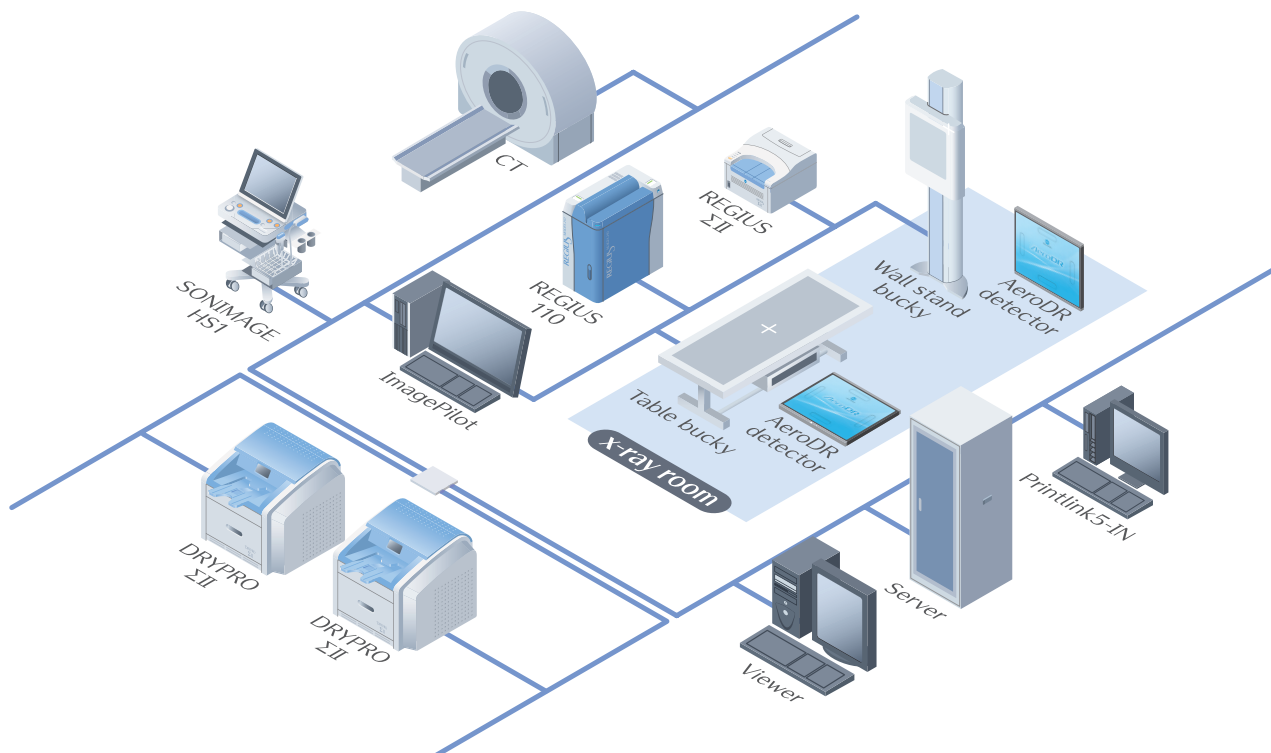

## PRODUCT SPECIFICATIONS

- Exposure source Semiconductor Laser
- Film size 14"x17"(35x43cm), 11"x14"(28x35cm), 10"x12"(25x30cm), and 8"x10"(20x25cm) selectable
- Film Dry Imaging Recording film SD-S / 125sheets per cartridge
- Pixel size 50µm (508 dpi)
- Processing capability 14x17-inch size sheets approximately 70 sheets/hour  
8x10-inch size sheets approximately 110 sheets/hour
- Network connection Ethernet 10 BASE-T / 100BASE-T / 1000BASE-T
- Film supply Daylight setting
- Number of supply trays 2ch
- Output grades 14bit (16384 grades)
- Network connectivity DICOM Print Management SCP
- Operating condition 15-33°C 20-80% RH, non-condensing
- Power 90-130V(50/60Hz) 9A / 180-264V (50/60Hz) 4.5A
- Dimensions W:626mm x D:649mm x H:666mm
- Weight 79 kg
- Footprint 0.41m<sup>2</sup>

## DIMENSIONS

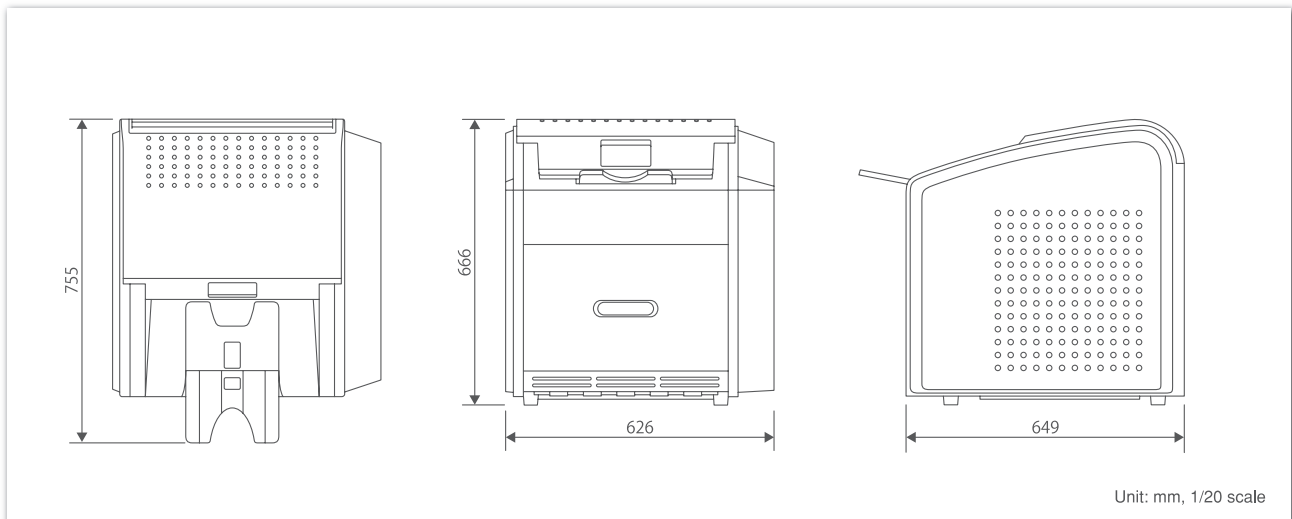

Brand Name : DRYPRO Σ II  
 Type : LASER IMAGER  
 Model : DRYPRO SIGMA 2

## Storing and handling unused film

Unused film should be stored in a cool, dark place (25° or below), where it will not be affected by radiation.

Your Konica Minolta Partner:

MEUN\_DPS2\_20160912